

MAIN FEATURES

- Long life and high reliability
- Strong construction for vibration and shock
- Approximately thousands for kinds are available depending on the combination of terminals, covers, contact ratings, coil etc.
- Molded material : All UL 94V-0
- UL & cUL recognized.

APPLICATIONS

- Power station control equipments
- Transportations
- Refrigerators
- Coil operated machines
- Office machines
- Building control equipments
- Medical equipments
- Amusement devices, etc.

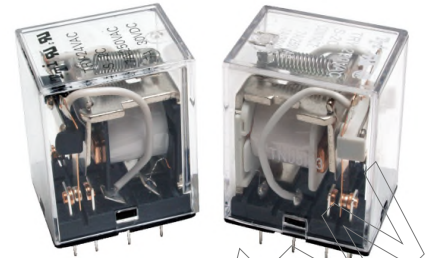

Option Socket :

Please refer appendix P101 · P102



- OD07-0004A (PYF-08AE)
- OD07-0005A (PYF-14AE)
- OD07-0006A (PYF-14A)
- OD07-0007A (PYF-08A)
- OD07-0008A (PY-08-02)
- OD07-0021A (PY-14-02)

ORDERING INFORMATION

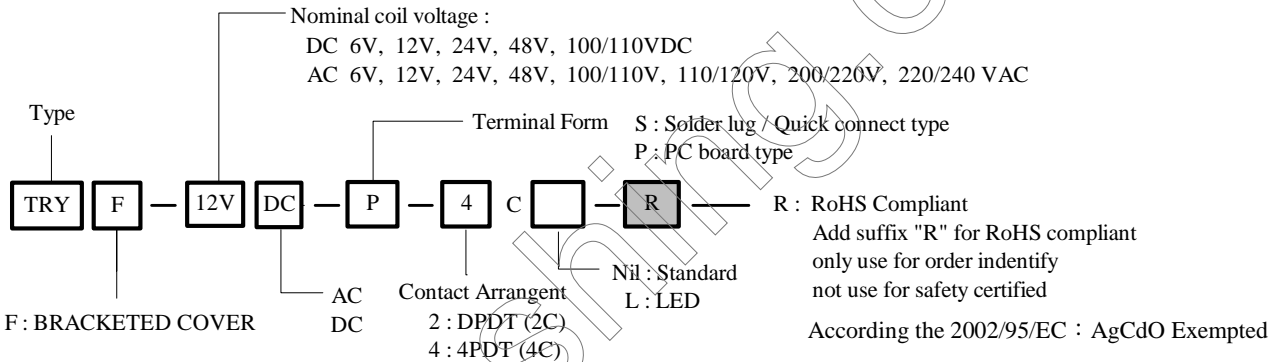

DIMENSION (unit:mm)

DRILLING (unit:mm)

WIRING DIAGRAM

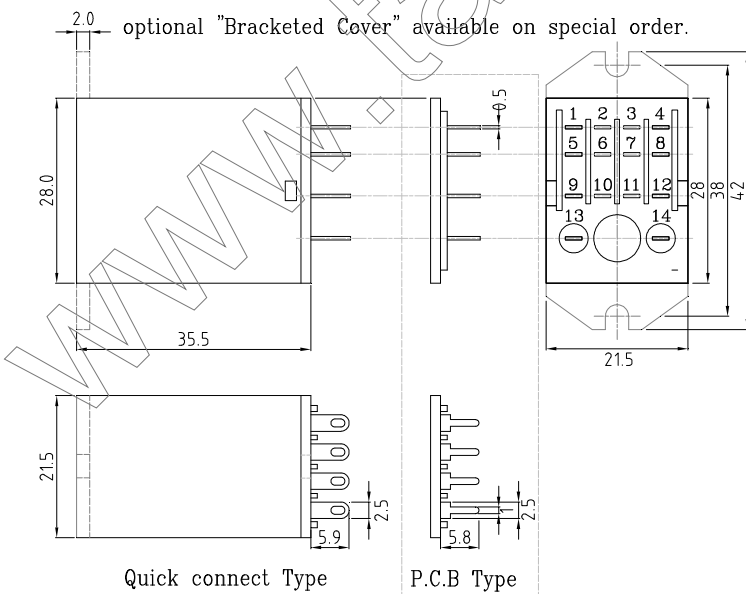

(Bottom views)

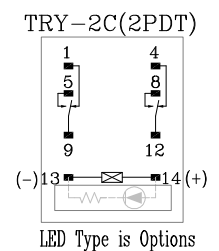
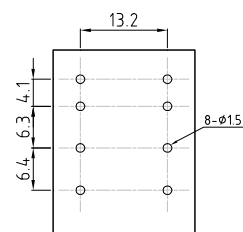
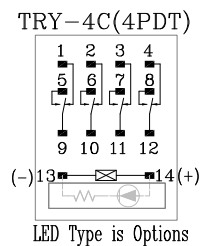
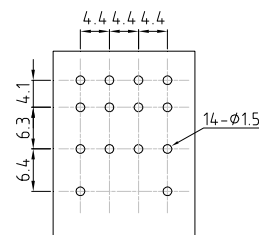

COIL DATA CHART (AT20°C)

Nominal voltage	Pick-Up voltage(Max.)	Drop-out voltage(Min.)	Nominal current	Coil resistance	Power consumption	Max. allowable voltage
AC Type (at 20°C)						
VAC	80% of rated voltage	30% of rated voltage	mA(+15%,-20%)	Ω ($\pm 10\%$)	(VA)	(VAC)
6	4.8	1.8	200	11.5	Approx. 1.2VA	110% of nominal voltage
12	9.6	3.6	100	46		
24	19.2	7.2	50	184		
48	38.4	14.4	25	735		
110	88	33	11	3750		
120	96	36	10	4550 $\pm 15\%$		
220/240	176/192	66/72	5	14400 $\pm 15\%$		
DC Type (at 20°C)						
VDC	80% of rated voltage	10% of rated voltage	mA($\pm 10\%$)	Ω ($\pm 10\%$)	(W)	(VDC)
6	4.8	0.6	150	40	Approx 0.9W	110% of nominal voltage
12	9.6	1.2	75	160		
24	19.2	2.4	36.9	650		
48	38.4	4.8	18.5	2600		
110	88	11	10	11000		

CONTACT RATING

Arrangement Item	TRY-2C	TRY-4C
	DPDT(2C)	4PDT(4C)
Contact Capacity	10A 220VAC	5A 220VAC
Resistive load $\cos\psi=1$	10A 28VDC	5A 28VDC
Max. switching voltage	220VAC, 28VDC	
Max. switching current	10A	5A
Max. switching power	2200VA, 280W	1100VA, 140W
Min. permissible load	5VDC 100mA	
Contact material	AgCdO	

PERFORMANCE (at initial value)

Contact Resistance	Max. 100m Ω
Operation time (at nominal voltage)	Max. 25msec
Release time (at nominal voltage)	Max. 25msec
Operating frequency	20ops/minute
Insulation resistance	Min. 100M Ω (at 500VDC)
Vibration resistance	Functional : 6G 10 to 55 Hz, at double amplitude of 1mm Destructive : 12G 10 to 55 Hz, at double amplitude of 2mm
Shock resistance	Functional : Min, 20G Destructive : Min, 100G
Dielectric strength	1500VAC. for 1minute between coil and contact. 750VAC. for 1minute between contact sets. 750VAC. for 1minute between open contacts.
Ambient temperature	-40 to +70°C
Humidity	40 to 85% RH
Life expectancy	Mechanical : 1 x 10 ⁷ operations Electrical : 2 x 10 ⁵ operations (at rated load)
Weight	abt 37grs.
UL & cUL	E156521

This datasheet for reference and subject to change without notice. Please double check final specification with Tai-Shing.
(0813AA06VOL02)