

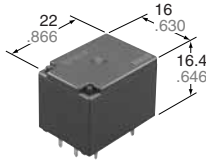

HIGH CAPACITY PC BOARD TYPE AUTOMOTIVE RELAY

CY RELAYS (ACY)



mm inch

FEATURES

1. 30 A nominal switching capacity

Capable of 30 A resistance load switching which is twice that of its predecessor of the same size (JSM Relay)

2. 30 A maximum carrying current

30 A/1 hour, 35 A/2 minutes at 20°C
25 A/1 hour, 30 A/2 minutes at 85°C
(for 450mW type, 14 VDC)

3. H/L type ideal for lamp loads

A H/L type is also available in which headlight load switching is possible (60 W × 2 lamps).

4. Designed to be environmentally friendly

With cadmium-free contacts and lead-free solder, environmentally harmful substances are not used.

TYPICAL APPLICATIONS

- Defoggers (for standard type)
- Heaters (for standard type)
- Headlights (for H/L type)
- Fog lamps (for H/L type)

Compliance with RoHS Directive

SPECIFICATIONS

Contact

Arrangement	1 Form C, 1 Form A, 1 Form A for H/L type	
Contact material	Ag alloy (Cadmium free)	
Initial contact resistance (Initial) (By voltage drop 6 V DC 1 A)	Typ. 8 mΩ (N.O.) Typ. 6 mΩ (N.C.)	
Rating	Nominal switching capacity	N.O.: 30 A 14 V DC N.C.: 15 A 14 V DC
	Max. carrying current	N.O.: For 450m W 30 A/1 hour, 35 A/2 minutes at 20°C 68°F 25 A/1 hour, 30 A/2 minutes at 85°C 185°F For 640m W 25 A/1 hour, 35 A/2 minutes at 20°C 68°F 20 A/1 hour, 30 A/2 minutes at 85°C 185°F N.C.: For 450m W and 640m W 20 A/1 hour, 25 A/2 minutes at 20°C 68°F 15 A/1 hour, 20 A/2 minutes at 85°C 185°F
	Min. switching capacity#1	1 A 12 V DC
Expected life (min. operation)	Mechanical (at 120 cpm)	Min. 10 ⁷
	Electrical (at rated load)	Standard type (resistive load): Min. 10 ⁵ *1 H/L type (lamp load): Min. 10 ⁵ *2

Coil

Nominal operating power	450m W (for Pick-up voltage: 7.2 V, Standard type) 640m W (for Pick-up voltage: 6.5 V, Standard type) 640m W (for Pick-up voltage: 7.2 V, H/L type)
-------------------------	--

#1 This value can change due to the switching frequency, environmental conditions, and desired reliability level, therefore it is recommended to check this with the actual load.

Characteristics

Max. operating speed (at nominal switching capacity)	6cpm	
Initial insulation resistance	Min. 100MΩ (at 500 V DC)	
Initial breakdown voltage*3	Between open contacts	500 Vrms for 1min.
	Between contacts and coil	1,500 Vrms for 1min.
Operate time*4 (at nominal voltage) (at 20°C 68°F)	Max. 10ms (initial)	
Release time*4 (at nominal voltage) (at 20°C 68°F)	Max. 10ms (initial)	
Shock resistance	Functional*5	Min. 100 m/s ² {10 G}
	Destructive*6	Min. 1,000 m/s ² {100 G}
Vibration resistance	Functional*7	10 Hz to 100 Hz, Min.44.1 m/s ² {4.5 G}
	Destructive*8	10 Hz to 500 Hz, Min.44.1 m/s ² {4.5 G}
Conditions in case of operation, transport and storage*9 (Not freezing and condensing at low temperature)	Ambient temp	-40°C to +85°C -40°F to +185°F
	Humidity	5% R.H. to 85% R.H.
Mass	Approx. 12g .42 oz	

Remarks

- *1 At nominal switching capacity, operating frequency: 1s ON, 9s OFF
*2 At 60 W x 2 lamps (Inrush: 70 A, Steady: 10 A 14 VDC), operating frequency: 1s ON, 14s OFF
*3 Detection current: 10mA
*4 Excluding contact bounce time.
*5 Half-wave pulse of sine wave: 11 ms; detection time: 10 μs
*6 Half-wave pulse of sine wave: 6 ms
*7 Detection time: 10 μs
*8 Time of vibration for each direction;
X, Y direction: 2 hours
Z direction: 4 hours



*9 Refer to Conditions for operation, transport and storage mentioned in AMBIENT ENVIRONMENT.
Please inquire if you will be using the relay in a high temperature atmosphere (110°C 230°F).

**ORDERING INFORMATION**Ex.

A

CY

--

--

3

12

Product name	Contact arrangement	Pick-up voltage, V DC	Coil voltage (V DC)
CY Relay	1: 1 Form C standard 3: 1 Form A standard 8: 1 Form A for H/L type	1: Max. 7.2 2: Max. 6.5	12: 12

Standard packing: Carton (tube package) 40pcs. Case 1,000pcs.

PRODUCT TYPES

Contact arrangement	Nominal voltage, V DC	Pick-up voltage, V DC (max. Initial) (at 20°C 68°F)	Part No.
1 Form C	12 V	7.2	ACY11312
1 Form A		6.5	ACY12312
		7.2	ACY31312
1 Form A for H/L type*		6.5	ACY32312
		7.2	ACY81312

Note) * H/L type: for head lights and fog lamps

TYPES AND COIL DATA (at 20°C 68°F)

	Nominal voltage, V DC	Pick-up voltage, V DC (max. Initial)	Drop-out voltage, V DC (min. Initial)	Nominal operating current, mA (±10%)	Coil resistance, Ω (±10%)	Nominal operating power, mW	Usable voltage range, V DC
Standard type	12	7.2	1.2	37.5	320	450	10 to 16
		6.5	1.0	53.3	225	640	
H/L type		7.2	1.2	53.3	225	640	



DIMENSIONS

1. Standard type

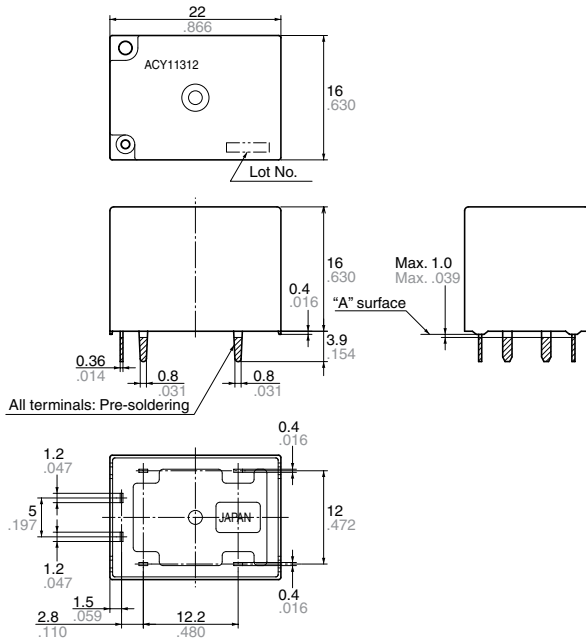

PC board pattern (Bottom view)

1 Form A

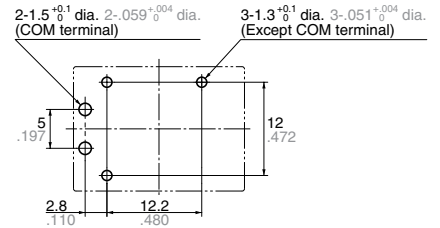

1 Form C

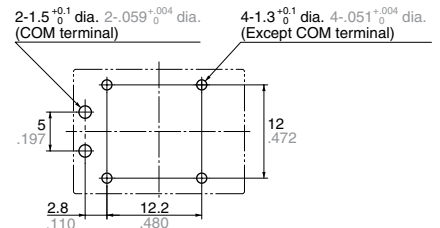

Tolerance: $\pm 0.1 \pm .004$

Schematic (Bottom view)

1 Form A

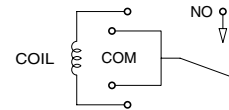

1 Form C

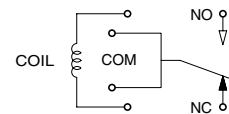

* Dimensions (thickness and width) of terminal specified in this catalog is measured before pre-soldering. Intervals between terminals is measured at A surface level.

2. H/L (1 Form A) type

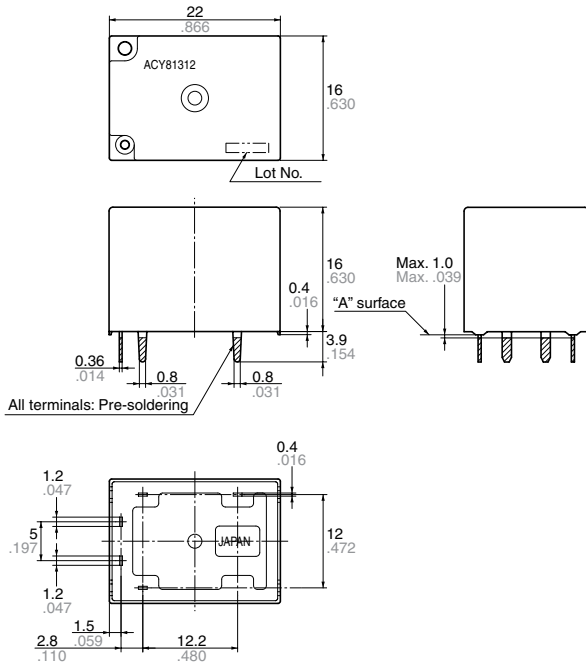

PC board pattern (Bottom view)

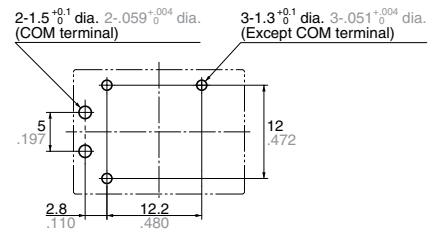

Tolerance: $\pm 0.1 \pm .004$

Schematic (Bottom view)

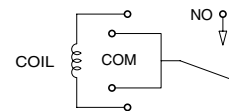

* Dimensions (thickness and width) of terminal specified in this catalog is measured before pre-soldering. Intervals between terminals is measured at A surface level.



REFERENCE DATA

1-(1). Coil temperature rise (at 27°C 80.6°F)
 Sample: ACY11312, 3pcs
 Measured portion: Inside the coil
 Ambient temperature: 27°C 80.6°F

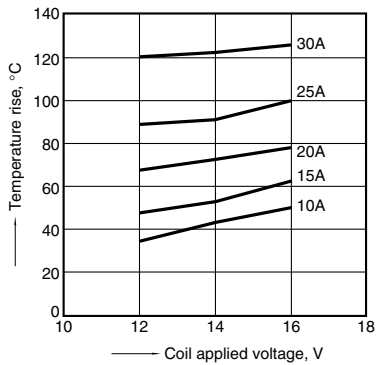

1-(2). Coil temperature rise (at 85°C 185°F)
 Sample: ACY11312, 3pcs
 Measured portion: Inside the coil
 Ambient temperature: 85°C 185°F

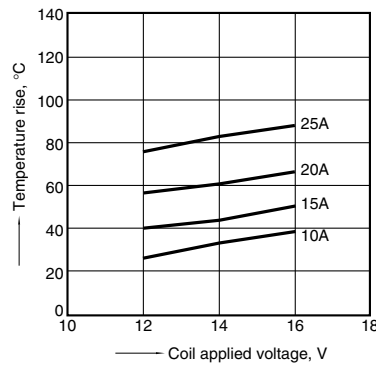

2. Ambient temperature and operating voltage range

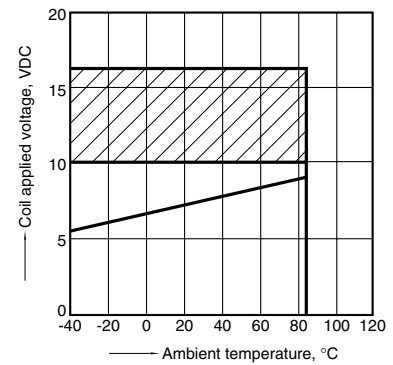

3-(1). Distribution of pick-up and drop-out voltage
 Sample: ACY11312, 20pcs.

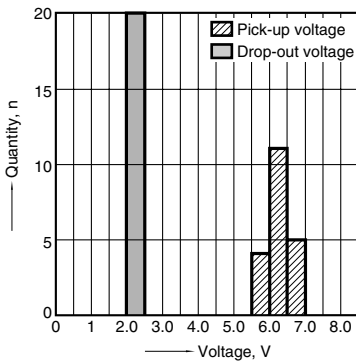

3-(2). Distribution of pick-up and drop-out voltage
 Sample: ACY12312, 20pcs.

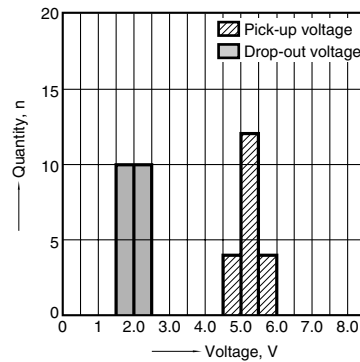

3-(3). Distribution of pick-up and drop-out voltage
 Sample: ACY81312, 20pcs.

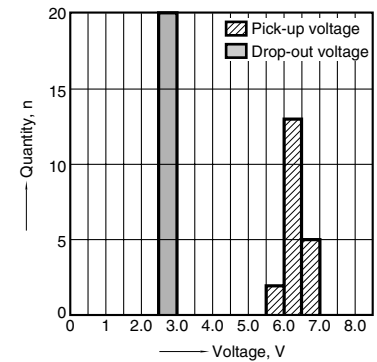

4-(1). Distribution of operate and release time
 Sample: ACY11312, 20pcs.
 Without diode

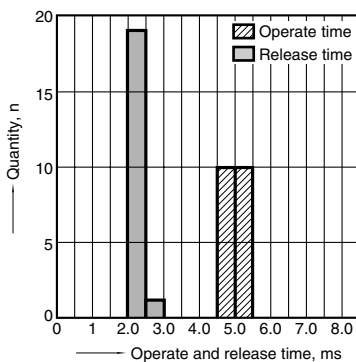

4-(2). Distribution of operate and release time
 Sample: ACY12312, 20pcs.
 Without diode

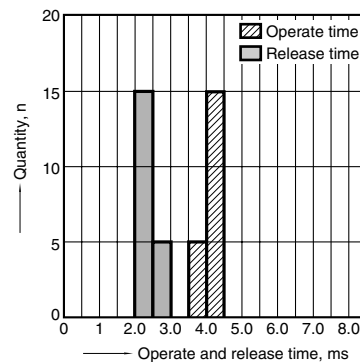

4-(3). Distribution of operate and release time
 Sample: ACY81312, 20pcs.
 Without diode

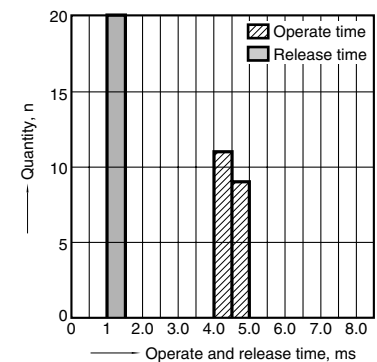

5-(1). Electrical life test (Resistive load)
 Sample: ACY11312, 6pcs.
 Load: Resistive load (NO side: 30A 14V DC)
 Operating frequency: (ON : OFF = 1s : 9s)
 Ambient temperature: Room temperature

Change of pick-up and drop-out voltage

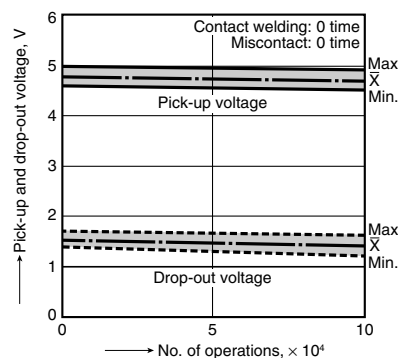

Change of contact resistance

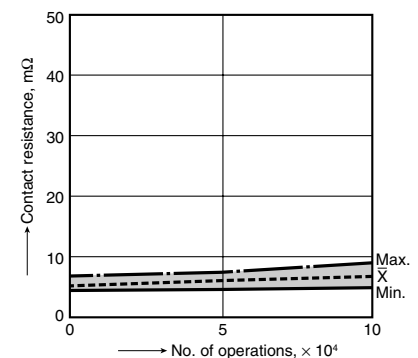



Discontinued as of August 31, 2010

CY (ACY)

5-(2). Electrical life test (Lamp load)

Sample: ACY81312, 6pcs.

Load: 60W×2, inrush: 70A/steady: 10A

Switching frequency: (ON : OFF = 1s : 14s)

Ambient temperature: Room temperature

Circuit

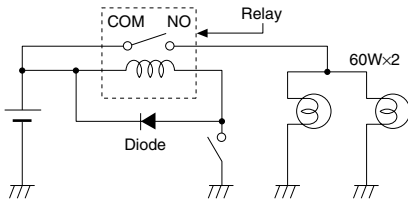

Change of pick-up and drop-out voltage

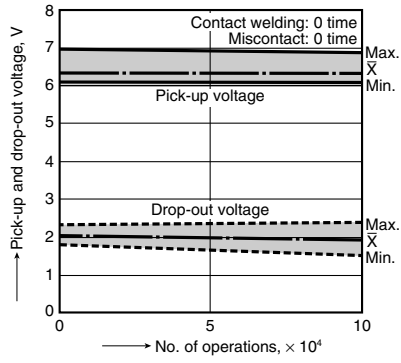

Change of contact resistance

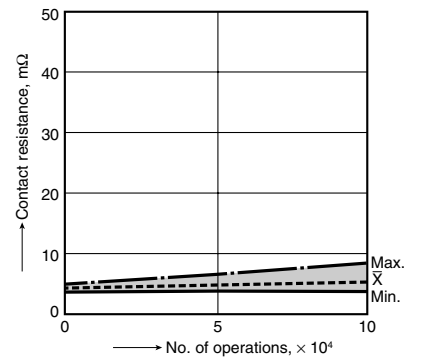

Load current waveform

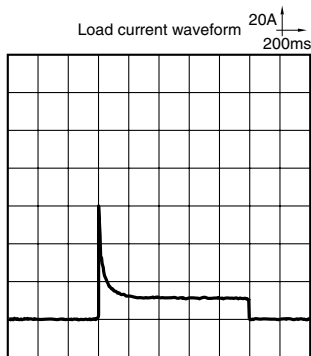

For Cautions for Use, see Relay Technical Information.