

HFK15-QH

AUTOMOTIVE RELAY



File No.: E133481



File No.: R50608985

Typical Applications

New energy charging system, PTC heating,
Electric motorcycle, Charging field, Energy storage field,
Inverter, UPS, BMS, OBS, Battery circuit breaker



Features

- Contact clearance above 3.0mm
- With auxiliary contact specifications
- DC specifications maximum breaking voltage 1000VDC
- Extended temp. Range up to 105°C
- Strong resistance ability to shock & vibration
- Reflow soldering version available
- Electricity safety meets the requirements of IEC60664-1
- RoHS, ELV compliant

CHARACTERISTICS⁽¹⁾

Contact arrangement	QH	
Voltage drop	Typ.:30mV(at 10A) Max.:250mV(at 10A)	
Main contact Max. continuous current ⁽²⁾	20A(at 105°C Rated voltage) 30A(at 85°C Rated voltage) 30A(at 105°C 50%Rated voltage) 40A(at 85°C 50%Rated voltage)	
Main contact Max. switching current	DC: 20A(Resistive,1000VDC) AC:20A(Resistive,277VAC)	
Main contact Max. switching voltage	DC: 1500VDC	
Min. contact load	Main contact	1A 12VDC ⁽³⁾
	Aux. contact	100mA 12VDC ⁽³⁾
Electrical load	See "CONTACT DATA"	
Mechanical endurance	3×10 ⁵ OPS	
Insulation resistance (initial)	1000MΩ(at 500VDC)	
Withstand voltage(initial)	3000VAC 1min(between contacts) 3000VAC 1min(main & aux.) 4000VAC 1min(coil & contacts)	
Operate time	Typ.:5ms	
	Max.:30ms	
Release time ⁽⁵⁾	Typ.:4ms	
	Max.:10ms	

Ambient temperature	-40°C to 105°C
Vibration resistance ⁽⁵⁾	Main contact: 10Hz to 55Hz, 1.5mm DA
Shock resistance ⁽⁵⁾	Main contact: 100 m/s ²
Termination	PCB ⁽⁶⁾
Construction	Plastic sealed, Flux proofed
Unit weight	Approx.25g

1) Initial value

2) The test under the follow conditions :

a. The relay is mounted on a PCB board

b. The PCB is a double layer board, the thickness of the copper foil is 4 oz(140μm), the width of each copper foil is 8.27×(1±5%)mm, the length of the copper foil is 50mm±1mm, and the Tg value of the PCB is 170°C or above.

3) The min. contact load is a reference value, which is applicable to environments with normal temperature, normal humidity and the on-off frequency, environmental conditions and expected. Therefore, please conduct a confirmation test with the actual normal pressure. This reference value will change according to load before use.

4) 1 min , leakage current less than 1mA.

5) The value is measured when voltage drops suddenly from nominal voltage to 0VDC and coil is not paralleled with suppression circuit.

6) Since it is an environmental friendly product, please select lead-free solder when welding. The recommended soldering temperature and time is (260±3)°C, (5±0.3)s.

CONTACT DATA⁽¹⁾

Load voltage	Load type	Contact arrangement	Load current Making ⁽²⁾	Load current Carrying ⁽²⁾	Load current Breaking ⁽²⁾	On/Off ratio		Electrical endurance OPS	Ambient temperature
			A	A	A	On s	Off s		
1000VDC	Resistive	DC product	5	5	5	0.6	5.4	3×10 ³	23°C
1000VDC	Resistive	DC product	20	20	0	0.6	5.4	1×10 ⁴	23°C
800VDC	Resistive	DC product	12.5	12.5	12.5	0.6	5.4	1×10 ⁴	23°C
450VDC	Resistive	DC product	40	40	40	0.6	5.4	3×10 ³	23°C
450VDC	Resistive	DC product	-20 ⁽³⁾	-20 ⁽³⁾	-20 ⁽³⁾	0.6	5.4	3×10 ³	23°C
450VDC	Resistive	DC product	20	20	0	0.6	5.4	5×10 ⁴	23°C
48VDC	Resistive	DC product	15	15	15	0.6	5.4	3×10 ³	23°C
277VAC	Resistive	DC product	16	16	16	1	9	1.5×10 ⁴	85°C
277VAC	Resistive	DC product	2	20	2	1	9	5×10 ⁴	85°C

Notes: 1) Load mentioned in this chart is for relays with no parallel diode or Zener Diode. For those with parallel diode, Zener Diode or other components, please contact Hongfa for more technical supports. Please also contact Hongfa if the actual application load is different from what mentioned above. All the rating are tested with open vent hole.

2) 0.6s/5.4s Making 100ms, carrying 400ms, breaking 100ms, 1s/9s Making 100ms, carrying 800ms, breaking 100ms.

3) "-" Indicates that the current direction is opposite to the requirements of the wiring diagram.

4) DC relay The Mounting spacing is 20mm when mounting side by side, and The Mounting spacing is 25mm when Mounting in the same row.



HONGFA RELAY

ISO9001, IATF16949, ISO14001, ISO45001, IECQ QC 080000, ISO/IEC 27001 CERTIFIED

2025 Rev. 1.00

COIL DATA

23°C

Nominal voltage VDC	Pick-up voltage VDC Max.	Holding voltage VDC	Drop-out voltage VDC Min.	Coil resistance $\times(1\pm 10\%)$ Ω	Power consumption W
6	4.8	3	0.5	25	1.44
12	9.6	6	1.0	100	1.44
24	19.2	12	2.0	400	1.44
48	38.4	24	4.0	1600	1.44

Notes:1) When the ambient temperature exceeds 85°C, the coil requires 120% of rated voltage excitation for 200ms, and after the relay is turned on and stabilized, the coil excitation voltage is reduced to 50% of rated voltage hold.

ORDERING INFORMATION

	HFK15-T/	A-	12-	QH	B	P	S	T	(XXX)
Type	HFK15-T: Reflow soldering version								
Load type	Nil: DC A: AC								
Coil voltage	6: 6VDC 12: 12VDC 24: 24VDC 48: 48VDC								
Contact arrangement	QH: 1 from X								
Monitoring contact Form	Nil: No auxiliary contact B: Auxiliary contact 1 from B								
Termination	P: PCB								
Construction	Nil: Flux proofed S: Plastic sealed								
Contact material	T: AgSnO ₂								
Special code	XXX: Customer special requirement				Nil: Standard				

Notes:1) Contact us for suitable soldering conditions and product specifications if post-soldering cleaning or surface treatment is required after the relays are soldered onto the PCB.

OUTLINE DIMENSIONS, WIRING DIAGRAM AND PC BOARD LAYOUT

Unit: mm

QH

Outline Dimensions

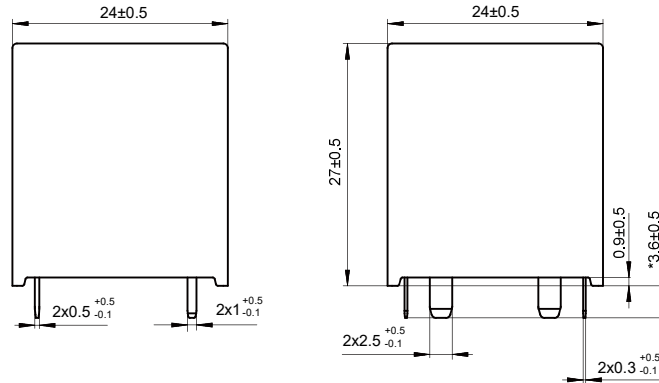

Notes:* The additional tin top is max. 1mm.

PCB Layout(Bottom view)

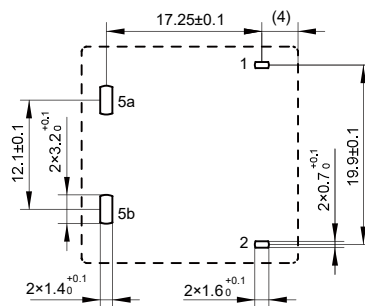

Notes:1) In case of no tolerance shown in outline dimension: outline dimension ≤ 1 mm, tolerance should be ± 0.2 mm; outline dimension > 1 mm and ≤ 5 mm, tolerance should be ± 0.3 mm; outline dimension > 5 mm and ≤ 30 mm, tolerance should be ± 0.4 mm; outline dimension > 30 mm, tolerance should be ± 0.6 mm;
2) The tolerance without indicating for PCB layout is always ± 0.1 mm.

Wiring Diagram(Bottom view)

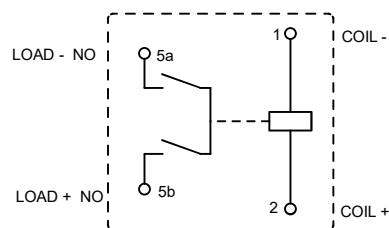

Notes: 1) DC type have polarity option on the loads and coil. If the loading polarity is connected reversedly, it will reduce loading switch performance, Please pay attention.
2) AC type have no polarity option on the loads and coil.

OUTLINE DIMENSIONS, WIRING DIAGRAM AND PC BOARD LAYOUT

Unit: mm

QHB

Outline Dimensions

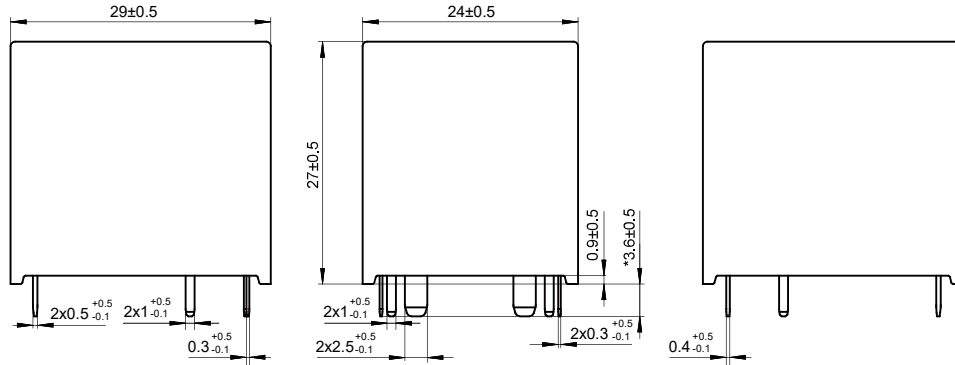

Notes:* The additional tin top is max. 1mm.

PCB Layout(Bottom view)

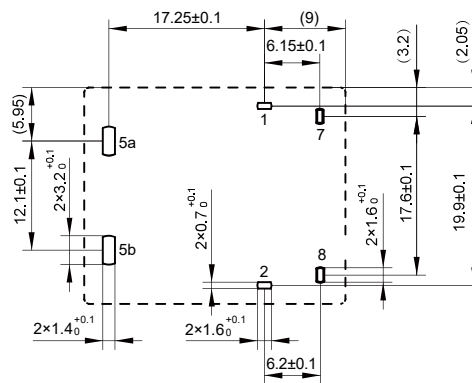

Notes:1) In case of no tolerance shown in outline dimension: outline dimension ≤ 1 mm, tolerance should be ± 0.2 mm; outline dimension > 1 mm and ≤ 5 mm, tolerance should be ± 0.3 mm; outline dimension > 5 mm and ≤ 30 mm, tolerance should be ± 0.4 mm; outline dimension > 30 mm, tolerance should be ± 0.6 mm;
2) The tolerance without indicating for PCB layout is always ± 0.1 mm.

Wiring Diagram(Bottom view)

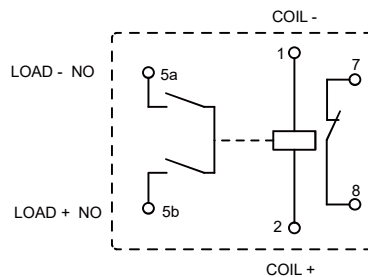

Notes: 1) DC type have polarity option on the loads and coil. If the loading polarity is connected reversedly, it will reduce loading switch performance, Please pay attention.
2) AC type have no polarity option on the loads and coil.

Disclaimer

The specification is for reference only. See to "Terminology and Guidelines" for more information. Specifications subject to change without notice. We could not evaluate all the performance and all the parameters for every possible application. Thus the user should be in a right position to choose the suitable product for their own application. If there is any query, please contact Hongfa for the technical service. However, it is the user's responsibility to determine which product should be used only.

© Xiamen Hongfa Electroacoustic Co., Ltd. All rights of Hongfa are reserved.